

## Pump Control Circuit for Automatic Tank Emptying

This diagram is for the circuit to empty a tank, using two normally open float switches and a two pole changeover relay. The bottom switch will be closed provided the liquid is above that switch point. The liquid rises until the top float switch closes and energises the relay. One set of relay contacts connects the pump to the supply and the other maintains the relay on-state, while the level falls towards the bottom switch. The relay will be held in the energised state until the bottom switch opens, so releasing the relay and cutting off the supply to the pump.

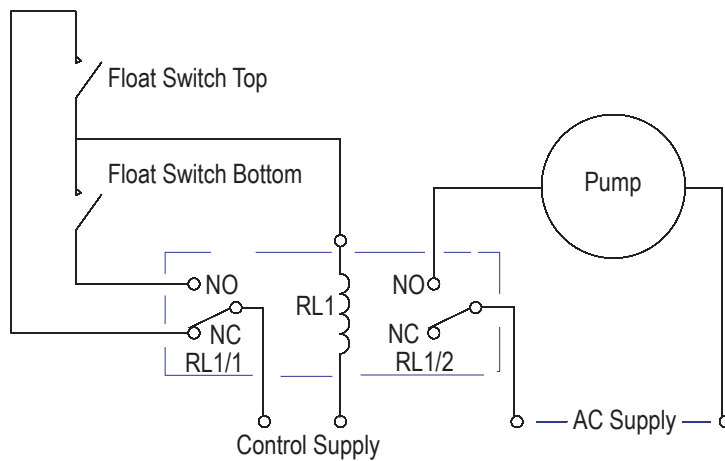

It is advisable to fit a 375V bi-directional Transil across the relay coil terminals, if the control voltage is 240V ac. A 1A Silicon Diode (IN4006) should be connected across the coil terminals, if the control voltage is DC (see diagram below). These measures are to avoid back EMF, induced over voltage transients, which can cause damage to the reedswitch contacts.

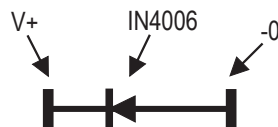

This circuit can also be used for controlling the filling of a tank, by using normally closed float switches and swapping the connections to the two float switches.

## Pump Control Circuit for Automatic Tank Filling

This diagram is for the circuit to fill a tank, using two normally closed float switches and a two pole changeover relay. The upper switch will be closed provided the liquid is below that switch point. The liquid falls until the lower float switch closes and energises the relay. One set of relay contacts connects the pump to the supply and the other maintains the relay on-state, while the level rises towards the top switch. The relay will be held in the energised state until the top float switch opens, so releasing the relay and cutting off the supply to the pump.

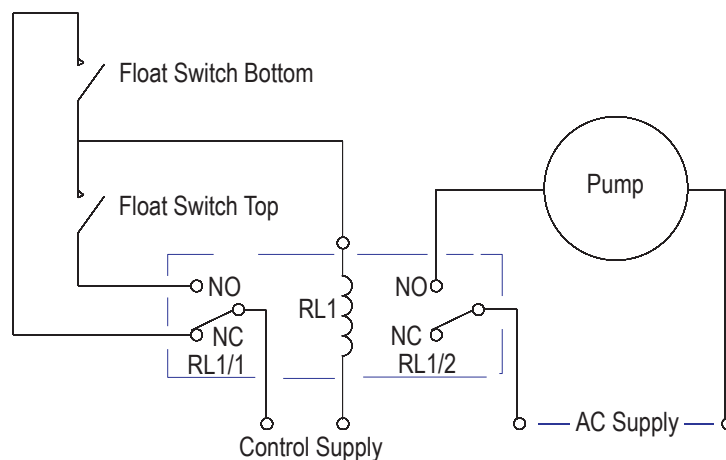

It is advisable to fit a 375V bi-directional Transil across the relay coil terminals, if the control voltage is 240V ac. A 1A Silicon Diode (IN4006) should be connected across the coil terminals, if the control voltage is DC (see diagram below). These measures are to avoid back EMF, induced over voltage transients, which can cause damage to the reedswitch contacts.

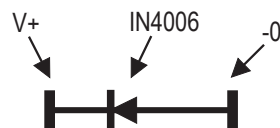

This circuit can also be used for controlling the emptying of a tank, by using normally open float switches and swapping the connections to the two float switches on the diagram above.