

IWR-1

Single Channel

Industrial Wireless Pressure/Temperature Receiver



Whilst every effort has been taken to ensure the accuracy of this document, we accept no responsibility for damage, injury, loss or expense resulting from errors or omissions, and reserve the right of amendment without notice.

This document may not be reproduced in any way without the prior written permission of the company.

Issue 2.1 September 2018

Cynergy3 Components Ltd.,
7 Cobham Road, Ferndown Ind. Est., Wimborne,
Dorset, BH21 7PE, UK
Tel: +44(0)1202 897969, email: sales@cynergy3.com
www.cynergy3.com

CONTENTS

1. INTRODUCTION	2
1.1 Safety Information	2
1.2 Hardware Features	2
2. UNPACKING	2
3. IWR-1 Receiver set up procedure	3
4. TROUBLE-SHOOTING GUIDE	5
5. SYSTEM PART NUMBERS	6
6. SPECIFICATIONS	6

1. INTRODUCTION

1.1 Safety Information

This manual contains information that must be observed in the interest of your own safety and to avoid damage to assets. Please read this manual before installing and commissioning the device and keep the manual in an accessible location for all users.

To satisfy FCC RF Exposure requirements for mobile and base station transmission devices, a separation distance of 20cm or more should be maintained between the antenna of this device and persons during operation. To ensure compliance operation at closer than this distance is not recommended. The antenna used for this transmitter must not be co-located or operating in conjunction with any other antenna or transmitter.

1.2 Hardware Features

The IWR range of Wireless Pressure & Temperature Receivers has been designed to receive the values from IWPT Wireless Pressure Transmitters and/or IWTT Wireless Temperature Transmitters and output the measured value as 4-20mA or 1-5Vdc analogue output signals.

The IWR-1 has a single output.

The IWR range of receiver units operate on the licence-free 2.4 GHz band.

Ranges of up to 500m are possible using the standard transmitter and receiver units with the supplied antennas. The actual achieved ranges can be adversely effected by obstacles (particularly metals), walls, trees, vehicles, etc., in between the transmitter and receiver.

The receiver is powered by a DC voltage of between 12-32Vdc.

2. UNPACKING

The instrument should be carefully inspected for signs of damage which may have occurred in transit. In the unlikely case that damage has been sustained, DO NOT use the instrument, but please retain all packaging for our inspection and contact your supplier immediately.

3. IWR-1 RECEIVER SET-UP PROCEDURE

The IWR-1 receives data from an IWPT or IWTT wireless transmitter and produces a 4-20mA or 1-5Vdc analogue source output representing 0 - 100% of the range of the transmitter connected.

It also has an alarm output that can be used as a high/low, loss of signal or low battery alarm.

As delivered the IWR-1 is configured to receive transmissions from an IWPT or IWTT wireless transmitter configured to channel 1.

3.1 Connections and Configuration Switches

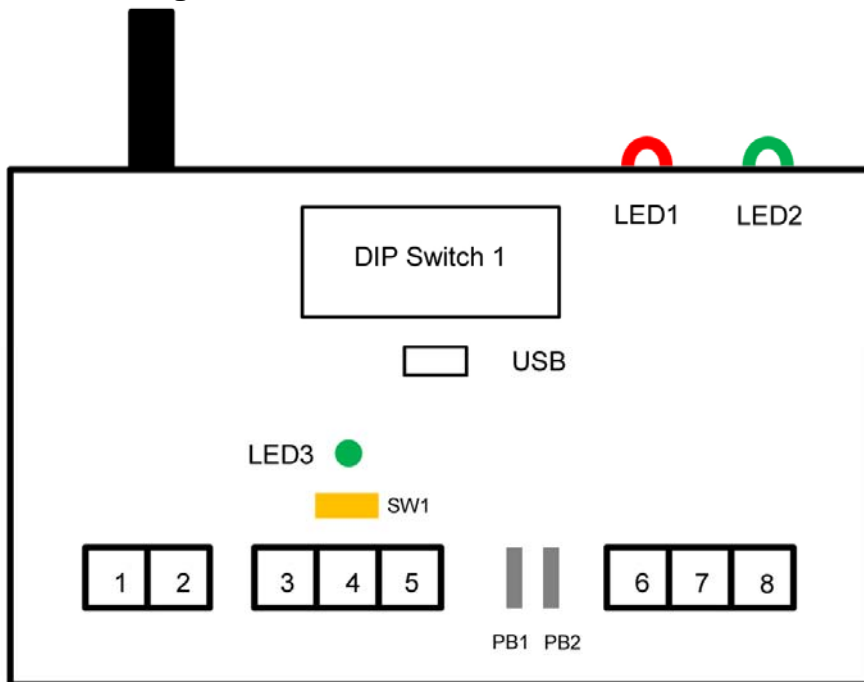

Terminal Number	Connection
1	Power 0V
2	Power +ve
3	Output 0V
4	mA Output +ve
5	1-5Vdc Output +ve
6	Relay Common
7	Relay N.C
8	Relay N.O

Dipswitch Configuration

The 8 way Dip Switch 1 is used to configure the basic functionality of the IWR-1
 The RF Network code must be the same as the Transmitter to be used with the Receiver unit.
 Switches 1, 2, 3 & 4 select the network code as below

RF NETWORK	1	2	3	4
1	0	0	0	0
2	0	0	0	1
3	0	0	1	0
4	0	0	1	1
5	0	1	0	0
6	0	1	0	1
7	0	1	1	0
8	0	1	1	1
9	1	0	0	0
10	1	0	0	1
11	1	0	1	0
12	1	0	1	1
13	1	1	0	0
14	1	1	0	1
15	1	1	1	0
16	1	1	1	1

Switches 5 and 6 select the number of transmissions which are missed before the Alarm relay output switches to the alarm condition or the analogue output changes to its burnout condition if a burnout option is configured using the IWR-SET software.

Missed Transmissions	5	6
4	0	0
2	0	1
6	1	0
No Alarm	1	1

Switches 7 and 8 configure the action of the Alarm Relay output. This can also be configured to the exact alarm values required using the USB port and the IWR-set software

Relay Action	7	8
Relay 1 switches OFF above 50%	0	0
Relay 1 switches OFF above 75%	0	1
Relay 1 switches OFF above 25%	1	0
Relay 1 Configured via USB & IWR-Set Software	1	1

LED Indication

External LED 1 is used to indicate the status of the alarm relay. This is lit if the value transmitted is outside the alarm limit, the receiver has missed the number of transmissions configured above or will flash if the transmitter has a low battery capacity.

External LED 2 flashes when a valid transmission is received from a connected transmitter.

The internal indicator LED3 is used to indicate the following alarm conditions:

LED flashes 2 times: This indicates that the number of transmissions missed has exceeded the number set up by switches 5 & 6 above.

LED flashes 3 times: This indicates that the transmitted value is outside the limits selected by switches 7 & 8 above.

LED flashes 4 times: This indicates the transmitter has a low battery level.

3.2 Output Calibration and Analogue Output Scaling

The IWR-1 is factory calibrated for 4-20mA and 1-5V source outputs so that if the transmits a zero or full scale output the IWR-1 output will be within its accuracy specifications.

The output selector switch is used to select either a 4-20mA or 1-5Vdc output. Push the switch SW1 to the left to select 4-20mA and to the right to select 1-5Vdc.

It is possible to adjust the output to match the equipment used to monitor the output or compensate for any zero or span drift of the transmitter. This is achieved by using the pushbuttons PB1 (DOWN) and PB2 (UP) and the internal LED as outlined here:

- Push both buttons at same time then release to put the unit into zero tare mode.
- LED will go amber, and the output will change to the zero value.
- Ensure there is no pressure/temperature applied to the connected transmitter and then use the DOWN and UP buttons to adjust the output to be 4mA or 1V
- If the led flashes amber this indicates that the connected transmitter zero value is not valid
- Push both buttons at same time again and then release.
- LED will go red to indicate that the full scale output will be adjusted. Inject the full scale pressure or temperature range into the transmitting sensor using a Calibrator. If no Calibrator is available press both buttons again to exit the calibration saving only the zero tare. The LED will go amber for 0.5 seconds as the zero tare value is learnt and saved to memory.
- If the full scale transmitter range can be applied use the DOWN and UP buttons to adjust the output to be 20mA or 5V. When the output is correct push both buttons at same time then release.
- If the LED flashes RED this indicates that the measured value is not close enough to the expected full scale value to allow successful calibration..
- If full scale calibration has been achieved the led will go amber for 0.5 seconds as calibration values are learnt and saved to memory.

The saved values will now be used to produce the calibrated analogue output.

The analogue output can be scaled to any part of the full scale range of the transmitter connected.

For example an IWTT with a P100 input sends a temperature back between -200°C & 800°C. By default the 4-20mA output will be at 4mA at -200°C and 20mA at +800°C. The IWR-Set V2.1 software can be used to scale the 4-20mA so that 4mA is output at a temperature of 0°C and 20mA is output at a temperature of +500°C.

The set up procedure is intuitive once the IWR-SET software is opened on a PC and connected to the IWR receiver using a standard micro USB cable.

If switches 5 & 6 are configured to switch the Alarm Relay if wireless transmissions are missed the analogue output can also be set to go to a failsafe burnout output if no transmissions are received.

If a 4-20mA output is selected the output will go to 2.2mA if Low Burnout is selected or 22.8mA if High Burnout is selected.

If No Action (the default setting) is selected the analogue output will stay at the last valid value received from the connected transmitter.

4. TROUBLE-SHOOTING GUIDE

Problem encountered	Possible Causes
LED2 doesn't flash	The IWR receiver is not connected to a transmitter or the transmitter is out of range.
mA Output reads zero	The IWR receiver output is not wired correctly, check wiring and try again
Output from IWR receiver isn't equivalent to the transmitter range being monitored	Check that the IWR receiver is linked to the correct transmitter by pressing the pushbutton inside the transmitter and checking that LED2 on the receiver flashes when the transmitter button is pressed. If the output still doesn't agree with the reading, re-calibrate the unit as described above.
LED1 is solid ON	This indicates that the reading from the transmitter is outside the limit selected or the receiver is out of range of the transmitter and transmissions are not being received.
LED1 is flashing	This indicates that the battery inside the transmitter is running low. Change the battery inside the transmitter taking care to exactly follow the procedure outlined in the transmitter manual.

5. SYSTEM PART NUMBERS

Pressure Transmitters		Temperature Transmitters	
Part Number	Pressure Range	Part Number	Transmitter Type
IWPT-G1000-00	0-1 Bar g	IWTP100A	PT100 6x100mm 1/4"BSP
IWPT-G6000-00	0-6 Bar g	IWTP150A	PT100 6x150mm 1/4"BSP
IWPT-GM1P9-00	-1-+9 Bar g	IWTP200A	PT100 6x200mm 1/4"BSP
IWPT-G1002-00	0-10 Bar g	IWTP250A	PT100 6x250mm 1/4"BSP
IWPT-G1602-00	0-16 Bar g	IWTP300A	PT100 6x300mm 1/4"BSP
IWPT-CO184-00	-1-+24 Bar g	IWTP400A	PT100 6x400mm 1/4"BSP
IWPT-G2502-00	0-25 Bar g	IWTTJ200A	J type 6x200mm 1/4"BSP
IWPT-G4002-00	0-40 Bar g	IWTTJ300A	J type 6x300mm 1/4"BSP
IWPT-G1003-00	0-100 Bar g	IWTTJ400A	J type 6x400mm 1/4"BSP
IWPT-G2503-00	0-250 Bar g	IWTTK150A	K type 6x150mm 1/4"BSP
IWPT-G4003-00	0-400 Bar g	IWTTK200A	K type 6x200mm 1/4"BSP
IWPTU-GP015-00	0-15 psi g	IWTTK300A	K type 6x300mm 1/4"BSP
IWPTU-GP030-00	0-30 psi g	IWTTK400A	K type 6x400mm 1/4"BSP
IWPTU-CO446-00	-14.5 to +150 psi g	IWTTUP100A	PT100 6x100mm 1/4"NPT
IWPTU-GP075-00	0-75 psi g	IWTTUP150A	PT100 6x150mm 1/4"NPT
IWPTU-GP100-00	0-100 psi g	IWTTUP200A	PT100 6x200mm 1/4"NPT
IWPTU-CO447-00	-14.5 to +350 psi g	IWTTUP250A	PT100 6x250mm 1/4"NPT
IWPTU-GP150-00	0-150 psi g	IWTTUP300A	PT100 6x300mm 1/4"NPT
IWPTU-GP300-00	0-300 psi g	IWTTUP400A	PT100 6x400mm 1/4"NPT
IWPTU-GP750-00	0-750 psi g	IWTTUJ200A	J type 6x200mm 1/4"NPT
IWPTU-GP1K5-00	0-1500 psi g	IWTTUJ300A	J type 6x300mm 1/4"NPT
IWPTU-GP3K6-00	0-3600 psi g	IWTTUJ400A	J type 6x400mm 1/4"NPT
IWPTU-GP5K8-00	0-5800 psi g	IWTTUK150A	K type 6x150mm 1/4"NPT
IWPTL-G0050-00	0-50mbar G	IWTTUK200A	K type 6x200mm 1/4"NPT
IWPTL-G0100-00	0-100mbar G	IWTTUK300A	K type 6x300mm 1/4"NPT
IWPTL-G0250-00	0-250mbar G	IWTTUK400A	K type 6x400mm 1/4"NPT
IWPTL-G0500-00	0-500mbar G		
IWPTL-G0750-00	0-750mbar G		
IWPTL-G1000-00	0-1000mbar G		
IWPTL-G0500-00	0-500mbar Abs		
IWPTL-G0750-00	0-750mbar Abs		
IWPTL-G1000-00	0-1000mbar Abs		
IWPTLU-GP001-00	0-1 psi g		
IWPTLU-GP002-00	0-2 psi g		
IWPTLU-GP005-00	0-5 psi g		
IWPTLU-GP008-00	0-8 psi g		
IWPTLU-GP010-00	0-10 psi g		
IWPTLU-GP015-00	0-15 psi g		
IWPTLU-GP005-00	0-5 psi Abs		
IWPTLU-GP010-00	0-10 psi Abs		
IWPTLU-GP015-00	0-15 psi Abs		

Part Number	Number of Output Channels
IWR-1	One
IWR-5	Five
IANT-3	3dBi Antenna
IWPT-SA	Swivel adaptor (1/4"BSP) for pressure transmitters only

6. SPECIFICATIONS

System Performance	
Accuracy (non-linearity & hysteresis)	<±0.25% / FS (BFSL)
Setting Errors	Zero & Full Scale, <±0.5% / FS
Operating Temperature	-20 to +50 °C
Storage Temperature	-20 to +80 °C
Outputs	4-20mA current source 1-5 Vdc voltage source
Relay	5A rated changeover contact
Enclosure Material	Light Grey ABS (RAL 7035)
Weight	215g
RF Transmitter	Contains FCC W&MRF24J40MDME
Power Requirements	12 to 32 Vdc
Fuse	Built-in resettable fuse
Dimensions	120 x 80 x 57mm (L x W x D)
Mounting	Any Orientation

**Cynergy3 Components Ltd.,
7 Cobham Road, Ferndown Ind. Est., Wimborne,
Dorset, BH21 7PE, UK
Tel: +44(0)1202 897969, email: sales@cynergy3.com**

www.cynergy3.com