



SC2002ALMHL

CONFIGURABLE DUAL TRIP AMPLIFIER

Whilst every effort has been taken to ensure the accuracy of this document, we accept no responsibility for damage, injury, loss or expense resulting from errors or omissions, and reserve the right of amendment without notice.

Cynergy3 Components Ltd

This document may not be reproduced in any way without the prior written permission of the company.

July 2017

| <u>CONTENTS</u> | <u>PAGE</u> |
|---|-------------|
| 1.0 INTRODUCTION | 3 |
| 2.0 UNPACKING | 4 |
| 3.0 CONNECTIONS | 5 |
| 4.0 TRIP CONFIGURATION | 6 |
| 5.0 INPUT RECONFIGURATION AND CALIBRATION | 8 |
| 6.0 SETTING TRIP POINTS | 9 |
| 7.0 INSTALLATION | 10 |
| 8.0 SPECIFICATIONS | 12 |

Industrial Interface Ltd
Signal House, Unit 15, Alstone Lane Trading Estate
Alstone Lane, Cheltenham,
Gloucestershire, GL51 8HF

Tel: 01242 251794, Fax: 01242 571683

www.industrialinterface.co.uk



1.0 INTRODUCTION

The SC2002ALMHL is a configurable trip amplifier capable of accepting a wide variety of electrical input types and providing two trip action relay outputs.

Input signal, trip configuration and power supply information are required to define any unit exactly. This information, together with a unique serial number is printed on the side label of each unit; records of the exact configuration of every product shipped are maintained at the factory.

1.1 Input Types And Ranges:

1.1.1 SC2002ALMHL

Accepts either DC voltage or current (i.e. high level) inputs.

In general the limits on signals that can be handled with the accuracy specified in section 8 are:

| FULL SCALE INPUT | MIN | MAX | MIN SPAN | NOTES |
|------------------|-------|--------------------------|----------------|---|
| DC CURRENT | 50µA | 5A | 50% FULL SCALE | MAX VOLTAGE DROP = 0.33V |
| DC VOLTAGE | 100mV | 60V (using a Divider) | 50% FULL SCALE | 10K ohm ≤ R in ≤ 10M ohm Use 2002-TC FOR Vin<100mV |

All the standard process ranges such as 0-10mA, 4-20mA, 0-20mA, 1-5V and 0-10V are of course covered.

1.1.1.1 Reconfigurable input option

The user-reconfigurable inputs are as follows: 0-10V, 0-5V, 0-20mA, 4-20mA and 0-10mA. Other input ranges can be factory configured, please call with your requirements.

1.2 Description of operation

The input stage of the SC2002ALMHL produces an internal process signal of 0 - 10V DC corresponding to the input span.

The trip set point potentiometers produce set point signals of 0 - 10V DC corresponding to the input span. These signals can be measured between terminal 7 (-ve) and terminal 9 for Setpoint 1 and terminal 12 for Setpoint 2. This enables setpoints to be accurately set without the need for an input simulator. 0-10 V corresponds to 0-100% of the input range.

Internal circuitry compares the process signal with each of the set point levels and changes the state of the output relays and indicator LED's as the signal passes through the set point, the exact action being factory or user configurable (see section 4).

A hysteresis band (typically 1% of span unless specifically requested) below each set point ensures chatter-free trip operation.

A block schematic diagram of the SC2002ALMHL is shown in Figure 1.

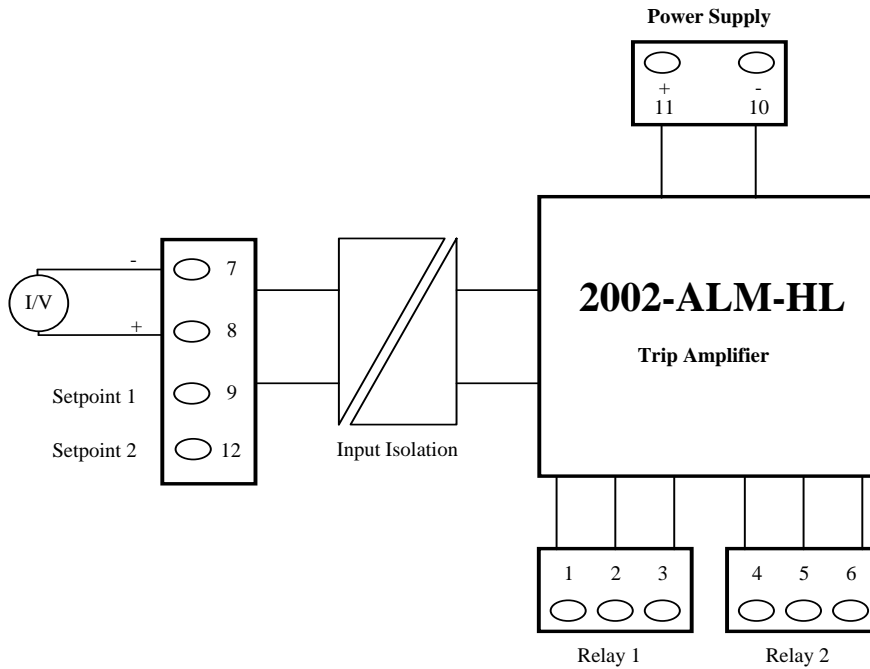

FIG. 1 - BLOCK SCHEMATIC DIAGRAM FOR THE 2002-ALM-HL TRIP AMPLIFIER

2.0 UNPACKING

Please inspect the instrument carefully for signs of shipping damage. The unit is packaged to give maximum protection but we can not guarantee that undue mishandling will not have damaged the instrument. In the case of this unlikely event, please contact your supplier immediately and retain the packaging for our subsequent inspection.

2.1 Checking the Unit Type

Each unit has a unique serial number label on which full details of the configuration are given (see Figure 2 for example). These details should be checked to ensure conformance with your requirement.

Figure 2 Input Connections

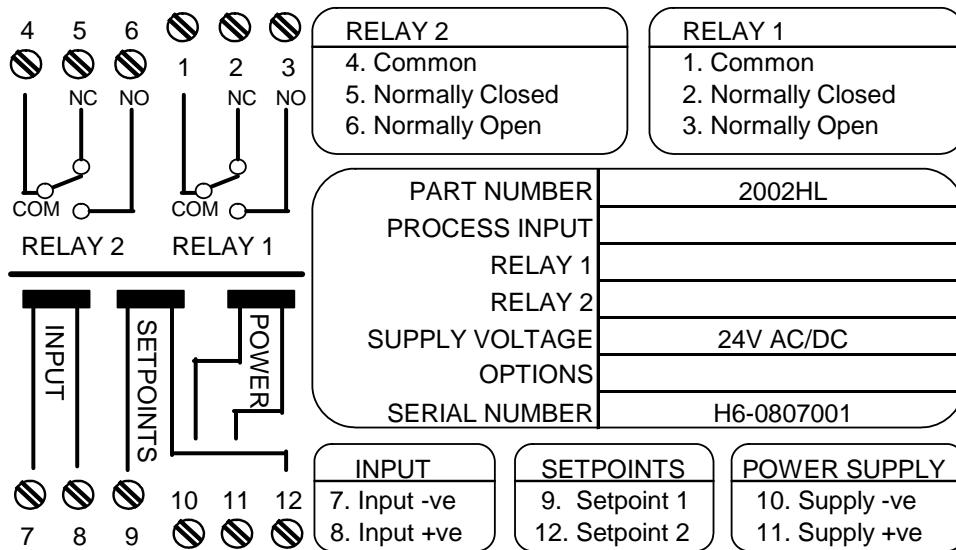

3.0 CONNECTIONS

This section details the instrument connection information. These details are also shown on the connections side label on each unit (see figure 2 above).

3.1 Power Supply

The power supply is connected into terminals 10 (negative) and 11 (positive). The supply voltage is indicated on the serial number label (Figure 2)

APPLICATION OF VOLTAGES HIGHER THAN THAT STATED FOR THE SUPPLY MAY CAUSE DAMAGE TO THE INSTRUMENT.

3.2 Sensor Connections

All sensor connections are made to terminals numbered 7 and 8 on the instrument. The inputs are connected as described below.

3.2.1 DC Voltage Inputs

The signal should be connected between pins 7 (negative) and 8 (positive).

3.2.2 DC Current Inputs

The signal should be connected between pins 7 (negative) and 8 (positive).

4.0 TRIP CONFIGURATION

4.1 Standard (non latching) operation

The action of each trip can be simply described by considering the state of the relevant relay and LED indicator with process signal either side of the trip set point. The options for each trip are as follows:

- | | | |
|----|--|--|
| a) | Relay energised for process signal above set point | LED on for process signal above set point |
| b) | Relay energised for process signal above set point | LED off for process signal above set point |
| c) | Relay energised for process signal below set point | LED on for process signal below set point |
| d) | Relay energised for process signal below set point | LED off for process signal below set point |

Thus any combination of fail safe or non fail safe options can be catered for.

4.1.2 Factory Pre-Configured Units

Where the unit is required for a preset trip configuration this can be requested at time of order and will be carried out free of charge at the factory. In this case the following convention, corresponding to option a to d above, is used for specifying operation:

- | | | |
|----|---------------------------|--------------------------|
| a) | $RLY\ x > SP\ x < LED\ x$ | |
| b) | $RLY\ x > SP\ x > LED\ x$ | Where $x = 1$ for trip 1 |
| c) | $RLY\ x < SP\ x > LED\ x$ | $x = 2$ for trip 2 |
| d) | $RLY\ x < SP\ x < LED\ x$ | |

This information will appear on the serial number side label on pre-configured units (figure 2). It is helpful if this convention is used by the customer when specifying units.

4.1.3 Default Configuration

In the event that pre-configuration information is not available, units will be shipped in default configuration as follows:

- | | |
|---------------------------|-----------------------|
| $RLY\ 1 > SP\ 1 < LED\ 1$ | (case a, section 4.1) |
| $RLY\ 2 < SP\ 2 > LED\ 2$ | (case c, section 4.1) |

4.1.4 User Configuration

If it is necessary to change the trip action of the instrument the instrument must be removed from the plastic enclosure. This is achieved by gently pressing on both lugs on the side of the black plastic box beneath the connection terminals, and withdrawing the circuit board from the enclosure.

The units may then be configured by changing the switch settings with reference to the diagrams in Figure 3 (see Section 5)

4.2 Latching Operation

Latching operation of relay 1 can be achieved by connecting link 1. Note that, where latching operation is specified, trip set point 2 is used to set the unlatch threshold such that Relay 2 is not independent. Latching operation is not possible with relay 2.

With Link 1 fitted, Relay 1 can be set to energise when the process signal rises above or falls below trip set point 1, in the normal fashion. At the same time LED 1 can be set to be on above or below set point 1. Once relay 1 has become energised it will remain energised so long as either the initial condition which caused the trip is sustained, or whilst relay 2 is de-energised, or both. i.e. relay 1 can only be latched whilst relay 2 is de-energised and can only be unlatched whilst relay 2 is energised. (Note that LED1 denotes whether the process signal is above or below trip set point 1, not whether relay 1 is energised.)

By way of example the latching mode of operation is likely to be used to maintain the process signal between an upper and a lower limit (for instance tank level control) as shown in Figure 4:

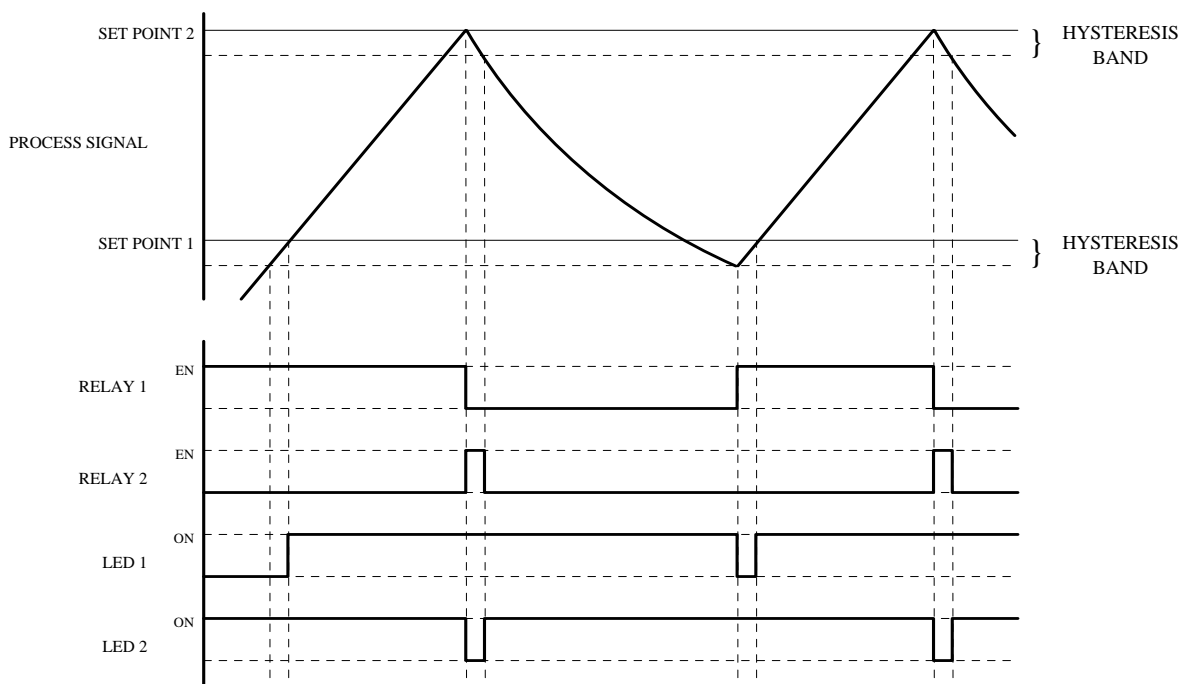

Fig. 4 - Timing Diagram - Latching Operation Of SC2002ALMHL

- Trip 1 is set to option d) (section 4.1)
- Trip 2 is set to option b) (section 4.1)
- Trip set point 1 is set to the lower allowable limit
- Trip set point 2 is set to the upper allowable limit

When the process signal is below set point 1 relay 1 is energised (latched) and will remain energised until the signal reaches set point 2. At this point relay 1 is unlatched (by relay 2 energising). As the process signal reduces relay 2 de-energises. As the signal falls below set point 1 relay 1 is energised (latched) again and the cycle repeats.

The LEDs can be used to indicate the status as follows:

| LED1 | LED2 | STATUS |
|------|------|-------------------------|
| OFF | OFF | Power Fail |
| OFF | ON | At or below bottom unit |
| ON | OFF | At or above top limit |
| ON | ON | Within limits |

5.0 INPUT RECONFIGURATION AND CALIBRATION

The SC2002ALMHL has a reconfigurable input. Reconfiguration can be carried out by changing the position of individual switches on the pcb and, for greatest accuracy, recalibrating the 0-10V internal process signal.

5.1 SC2002ALMHL Reconfiguration and Calibration

- (i) Referring to SC2002ALMHL switch setting diagram (figure 3), set switches 1 through 8 on switches S1, S2 and S3 as required
- (ii) Connect voltmeter between connector terminals 7 (-ve) and the Voltage Adjust point shown in Figure 3.
- (iii) Connect a current or voltage source as appropriate to input terminals 7 (-ve) and 8 (+ve)
- (iv) Adjust Zero pot to give 0.00V on voltmeter at zero scale for 4-20mA range only - zero is automatic for other ranges
- (v) Adjust Span pot to give 10.00V on voltmeter at full scale
- (vi) Repeat (iv) and (v) as necessary.

Figure 3 User-Configuration

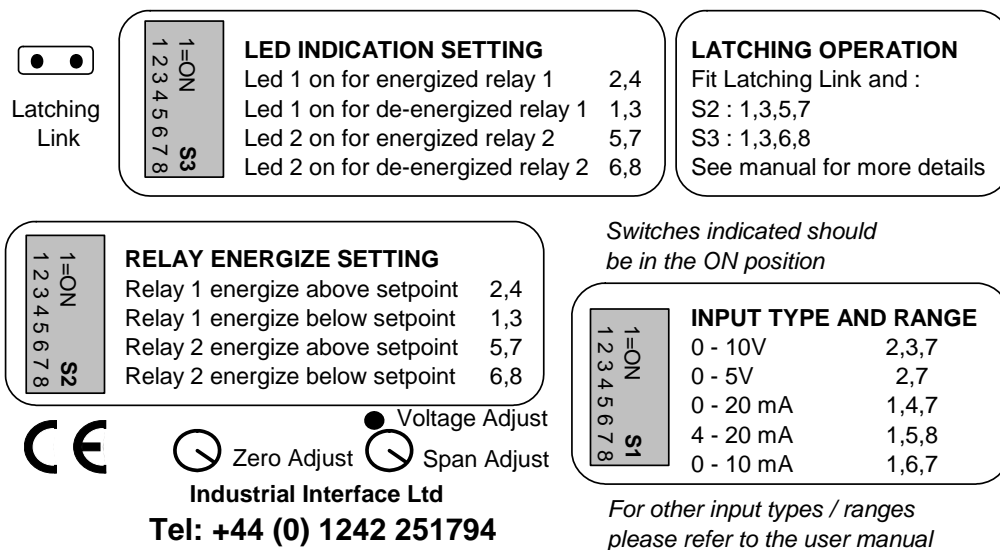



6.0 SETTING TRIP POINTS

The trip points can be measured between connection terminal 7 and terminal 9 for Setpoint 1 and terminal 12 for Setpoint 2. The measured signal is a voltage between 0 and 10V corresponding to 0-100% of the input range of the unit.

6.1 SC2002ALMHL Trip Points

Since the 0-10V process signal is linear for this device the trip point is equal to 100% of span multiplied by the set point voltage

e.g. 4-20mA input
trip at 16mA input = 75% of span
therefore trip set point = 7.50V

7.0 INSTALLATION

Fig. 5 - Installation Data & Terminal Positions For SC2002ALMHL

Installation Data

Mounting DIN Rail T35
 Orientation Any (Vertical Preferred)
 Connections Screw Clamp With Pressure Plat
 Conductor Size 0.5mm - 4.0 mm
 Insulation Stripping 10mm
 Screw Terminal Torque 0.4Nm Max.
 Weight 120g (approx.)

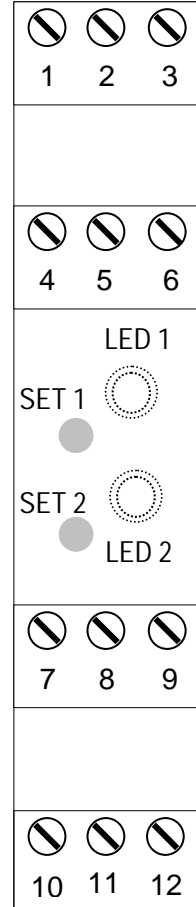

| <u>Terminal No</u> | <u>SC2002ALMHL</u> |
|--------------------|------------------------------------|
| 1 | Relay 1 common |
| 2 | Relay 1 n/c |
| 3 | Relay 1 n/o |
| 4 | Relay 2 common |
| 5 | Relay 2 n/c |
| 6 | Relay 2 n/o |
| 7 | Process input -ve Setpoint -ve |
| 8 | Process input +ve |
| 9 | Setpoint 1 +ve (0 – 10Vdc) |
| 10 | Power supply -ve |
| 11 | Power supply +ve |
| 12 | Setpoint 2 +ve (0 – 10Vdc) |



7.1 Installation onto Rails

The instrument is designed to mount directly onto the "Top hat" TS35 standard assembly rail to DIN46277 part 3/EN 50022/BS5584.

7.2 Mounting Arrangements

Ideally the unit should be mounted in a vertical position, i.e. on a horizontal rail. This is the optimum orientation to minimise temperature rise within the unit. However successful operation is possible in any orientation.

Ensure the maximum ambient temperature is less than 55°C.

Good airflow around the unit will maximise reliability.

7.3 Wiring Precautions

These units can accept a variety of sensor inputs, some of which produce very small voltages. Therefore it is advisable to adhere to the following rules of good installation practice:

- (i) Do not install close to switchgear, electromagnetic starters, connectors, power units or motors.
- (ii) Do not have power or control wiring in the same loom as sensor wires.
- (iii) Use screened cable for sensor wiring with the screen earthed at one end only.
- (iv) Take care not to allow cut pieces of wire to fall onto the unit as they might enter via the ventilation holes and cause electrical short circuits. If in doubt, remove the units from the rail until wiring is complete.
- (v) Use bootlace ferrules on all bare wires.

IMPORTANT: The connection terminals are designed for a maximum torque of 0.4Nm. Exceeding this figure is unnecessary and will result in unwarrantable damage to the unit.

8.0 SPECIFICATIONS

All specifications are at 20 °C operating ambient unless otherwise stated.

8.1 Accuracy and Response

8.1.1 SC2002ALMHL

| | |
|---|--------------------------|
| Process signal linearity | +/- 0.1% full scale |
| Trip point accuracy | +/- 0.25% range |
| Hysteresis | -1% full scale standard |
| Process signal drift | +/- 100ppm full scale/°C |
| Trip point drift | +/- 100ppm/°C |
| Signal Response Time (90% of step change) | 2ms typical |
| Relay response time | 10ms typical |

8.2 Power Supply Isolation and Operating Ambient

| | |
|---|----------------------|
| Operating Voltage | 24V DC or AC +/- 10% |
| Current consumption * | 45mA typical |
| Input to power supply isolation | 1kV DC |
| Input and power supply to relay contact isolation | 2kV RMS AC |
| Operating temperature range | 0-55°C |
| Storage temperature range | -40 - 100°C |
| Operating and storage humidity range | 0 - 90% RH |

* Both relays energised

8.3 EMC

| | |
|---------------|------------|
| EMC | BS EN61326 |
| LVD Standards | EN61010-1 |